



DOSATRON®

WATER POWERED DOSING TECHNOLOGY

8 m³/h

D 8 R - 0.2 - 2 %



SPECIFICATIONS

- Injection Range :
 - 0.2 - 2 %
 - [1 : 500 - 1 : 50]
 - Water flow range* :
 - 500 l/h - 8 m³/h
 - [8.33 l/mn - 133.3 l/mn]
 - [2.2 US GPM - 40 US GPM]
 - Operating pressure :
 - 0.15 - 8 bar
 - [2 PSI - 110 PSI]
 - Concentrated additive injection :
 - 1 l/h - 160 l/h
 - [0.56 US Fl oz/min - 0.70 US GPM]
- * For operating unit with other fluids than water, please contact us

A unique technology associating all dosing functions

Dosing Technique :

Non-electric proportional

Energy Source :

Water flow and pressure

Integrated functions :

- Metering : volumetric hydraulic motor
- Injecting : continuous proportional injection of liquid or soluble concentrate
- Regulating : proportionality servo-controlled by the water flow
- Mixing : integrated mixing

Package contents :

- 1 Dosatron, 1 wall bracket,
- 1 Suction tube 175 cm [69"]
- Ø 6 X 9 mm [1/4" id X 3/8"od]
- 1 Owner's manual.

8 m³/h - 0.2 - 2 %

Operating principle

Installed directly in the water supply line, the Dosatron operates by using the flow of water as the power source. The water activates the Dosatron, which takes up the required percentage of concentrate directly from the container and injects it into the water. Inside the Dosatron, the concentrate is mixed with the water, and the water pressure forces the solution downstream. The dose of concentrate will be directly proportional to the volume of water entering the Dosatron, regardless of variations in flow or pressure, which may occur in the main line.

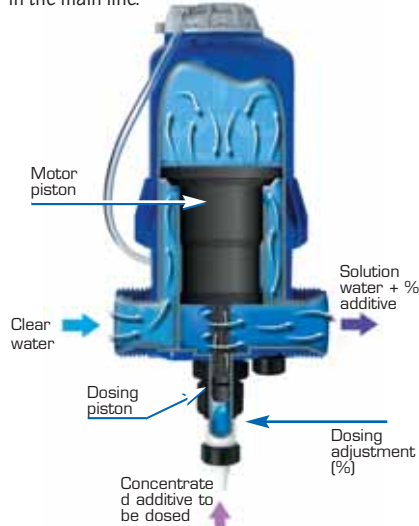

Proportional injection externally adjustable



The injection rate is set by lining down the top of the adjusting sleeve with the desired ratio on the scale. The amount of injected concentrate is proportional to the amount of water coming into the Dosatron :



i.e. Adjustment at 1% = 1 : 100 = 1 Volume of concentrate into 100 Volumes of water.

Dosatron, a complete range

Dosatron develops, manufactures and markets a unique dosing technology that allows any liquid or soluble concentrate to be continuously and proportionally injected and mixed into water.

The 8 m³/h range

REF. ADJUSTABLE	DOSAGE	PRESSURE
D 8 R	0.2 - 2 %	0.15 - 8 bar
D 8 R 150	1 - 5 %	0.15 - 8 bar

Other product lines available to treat water flows up to 1.5 m³/h, 2.5 m³/h, 4.5 m³/h, 20 m³/h, 30 m³/h, 60 m³/h,....
For special models, accessories and particular systems: please consult us.

Specifications

General	
- Maximum operating water temperature :	40°C [104° F]
- Minimum operating water temperature :	5° C [41° F]
- Dosing rate :	i.e. Adjustment at 1 % = 1:100 = 1 V concentrate into 100 V water +/- 5 % (Charts on demand)
- Average dosing accuracy :	+/- 3 % (API standard)
- Repeatability :	0.2 - 0.7 Bar [2.9 - 10.15 PSI] (depending on operating conditions)
- Pressure loss :	
Other integrated functions	
- Internal motor filter :	500 microns [32 mesh]
- Inlet/Outlet :	compression adaptors 1 1/2 M Ø40x49 mm
- Built-in by-pass :	yes - supplied with hose Ø 6 x 9 mm [1/4" id x 3/8" od]
- Built-in airbleeder :	yes
- Built-in anti-siphon device :	yes
Motor	
- Motor :	differential hydraulic piston
- Motor capacity :	1.6 L [0.4224 US Gallons] (1 cycle)
- Mixing chamber :	integrated
Dosing	
- Injection :	internal at the outlet
- Dosing plunger :	simple action, injection on the upstream
- Injection check valve :	spring-loaded cone
Suction	
- Self-priming :	yes
- Maximum viscosity of concentrate :	400 cSt at 20°C [68° F] - V Kit recommended from 200 cSt
- Maximum vertical or horizontal suction of the concentrate :	4 m [13 ft]
- Strainer :	yes - foot strainer with weight

Markets

Environment - Hygiene - Water treatment - Vehicle wash - Metal processing - Food processing - Graphic Arts - Horticulture - Livestock...

Principal applications :

Medication - Disinfecting - Cleaning - Fertigation - Phytosanitation - Supplementation - Lubrication - PH/TH Correction - Sanitation - Flocculation - Vehicle wash...

Installation

Regulations : Refer to local water regulations, prior to installing your Dosatron.

To optimize your Dosatron, we advise to :

- Install a filter (300 mesh [60 microns]) upstream, depending on your water quality.
 - Change the dosing seals once a year.
 - Rinse as often as possible with clear water.
 - Turn off the water supply and allow the pressure to drop to zero before adjusting the injection rate.
 - Install necessary protections for excess flow, excess pressure and water hammer (anti-hammer flow/pressure device).
 - Install your Dosatron on a total by-pass line.
- For all other installation advice, please consult us.

Size :

- Package size : 60 x 36.5 x 24 cm [23 2/3" x 14 1/3" x 9 1/2"]
- Package weight : ~ 5.5 kg [~ 12.15 US lbs]

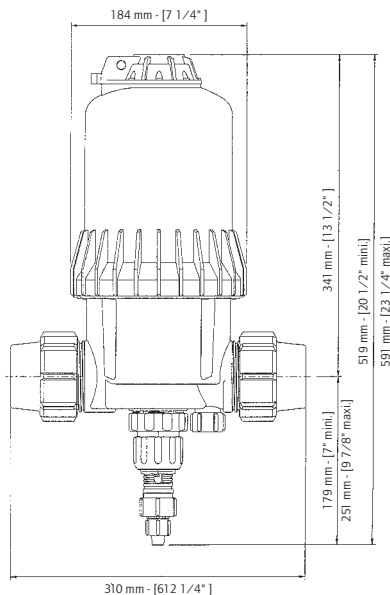

Standard material

Housing : polyacetal, EPDM
 Motor piston : polyurethane, nylon, EPDM, polyacetal
 Injection area : polypropylene, polyethylene, hastelloy (check valve spring)
 Injection hose : PVC

Available options

(■ : Option ● : standard ★ : not available for this model)

Optimized compatibility

- AF : Recommended seals for alkaline concentrate
- VF : Recommended seals for acid concentrate
- ★ PVDF : Housing
- ★ H : Hastelloy plunger rod (not needed for this model)
- ★ IE : External injection
- V : Kit for viscous concentrate
- Injection hose : Special material hose and foot strainer available

BSP



NPT



Adaptors.

Optimized installation

- BP : integrated by-pass
- Other fittings
- ★ Strap
- Support legs
- Other : please contact us



4 legs + 1 dosing unit support.

These options allow adapting your Dosatron to your needs. Contact our technical service to help determine what option you may need.

Each Dosatron unit is factory tested.

CUSTOMER SERVICE - SERVICE CLIENTÈLE

DOSATRON INTERNATIONAL S.A.S.

Rue Pascal - B.P. 6 - 33370 TRESSSES (BORDEAUX) - FRANCE
 Tel. 33 (0)5 57 97 11 11 - Fax. 33 (0)5 57 97 11 29 / 33 (0)5 57 97 10 85
 e.mail : info@dosatron.com - http://www.dosatron.com

This document does not form a contractual engagement on the part of Dosatron International and is for information only. Dosatron International reserves the right to alter product specification or appearance without prior notice. © DOSATRON INTERNATIONAL S.A.S. 2003.

FT / D8R-GB / 07 / 08

AKS 3000P - Crédit photos : DOSATRON - Studio C. Prigent